

Here all the C major scale patterns on the bass fingerboard ordered from open to 12th position. This sequence is true for any key. Open position repeats at 12th fret and the sequence starts over.

R = root, all other numbers signify scale steps. Chord tones (notes of the C major arpeggio) are yellow- **5**

(b7) = flat 7th, which is used in place of the major 7th **7** when playing a bass line for a dominant 7th chord (A7, E7, etc.)

Notes
On
Open
strings

I

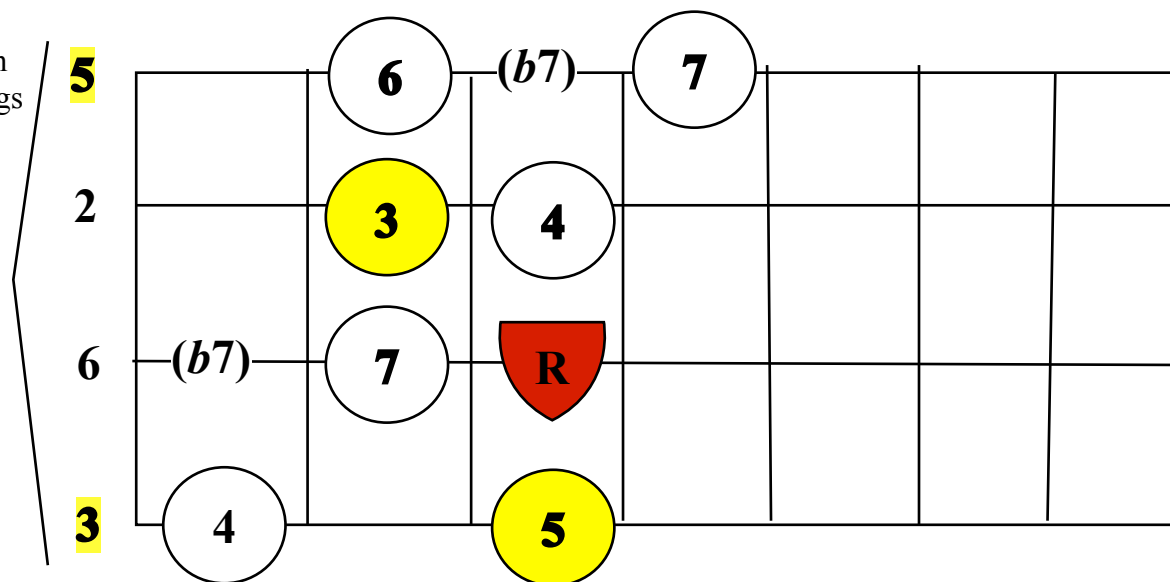

I

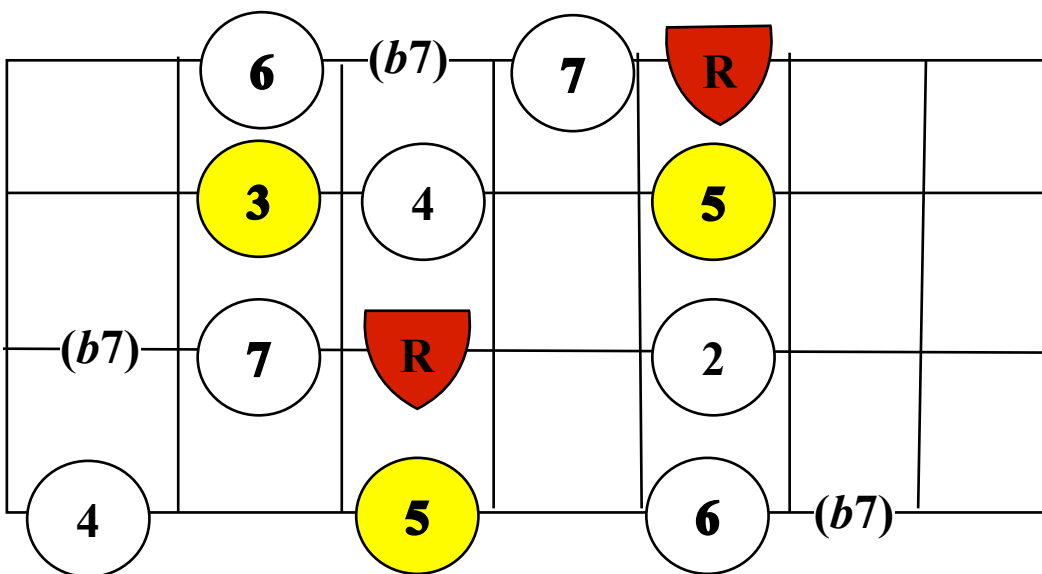

This one's a bit of a stretcher. Not everyone uses it but its good to know.

III

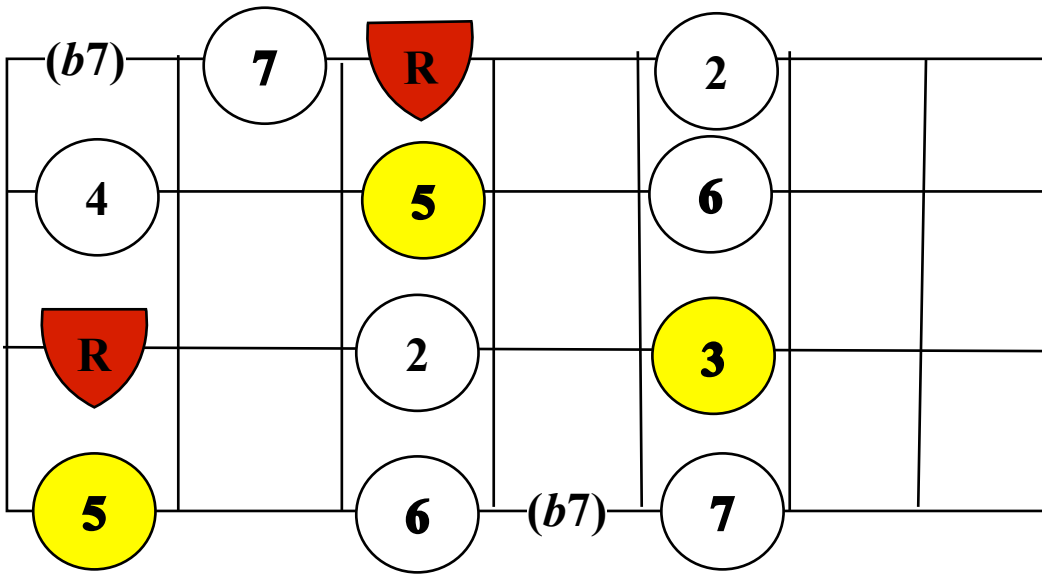

V

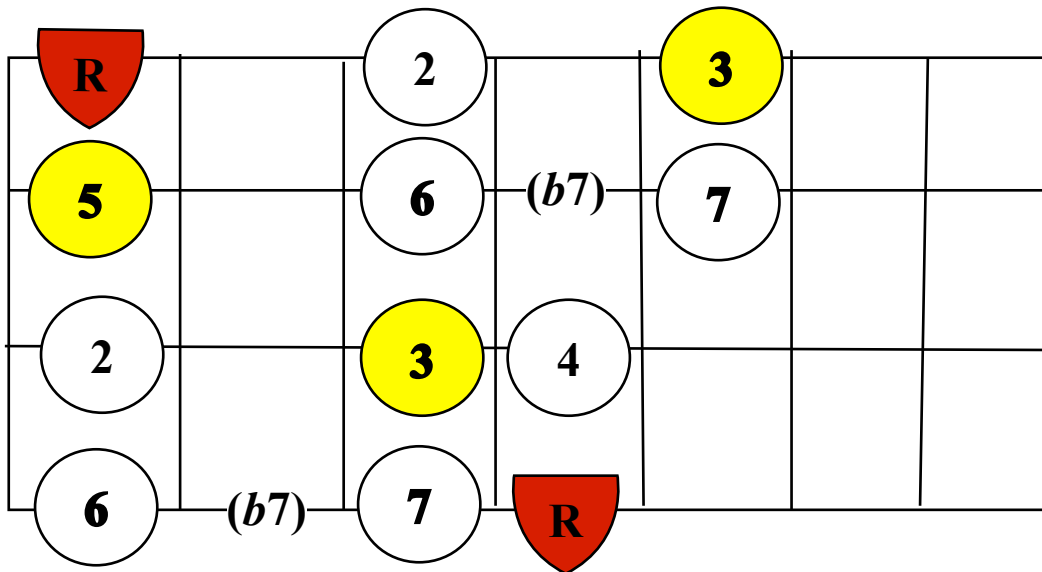

VII

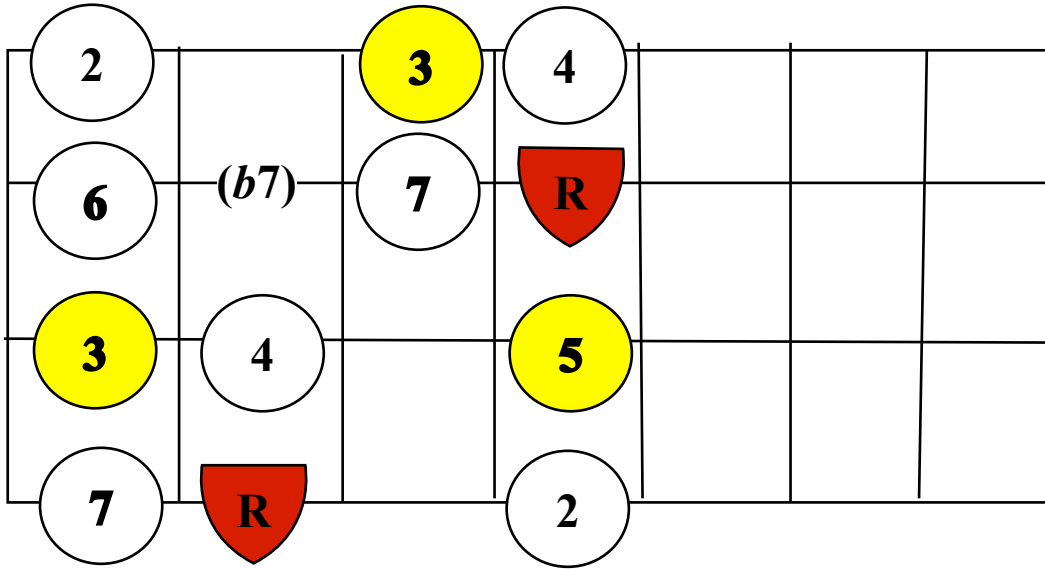

Here's another "stretcher." Stay relaxed. These might take more time to work in than the others. Don't let it hang you up.

VIII

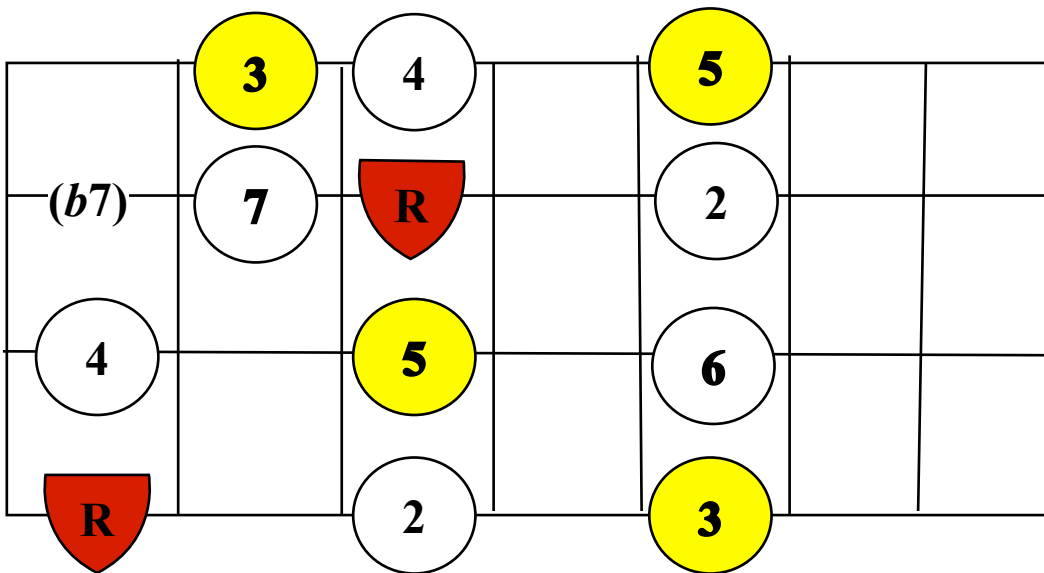

VIII

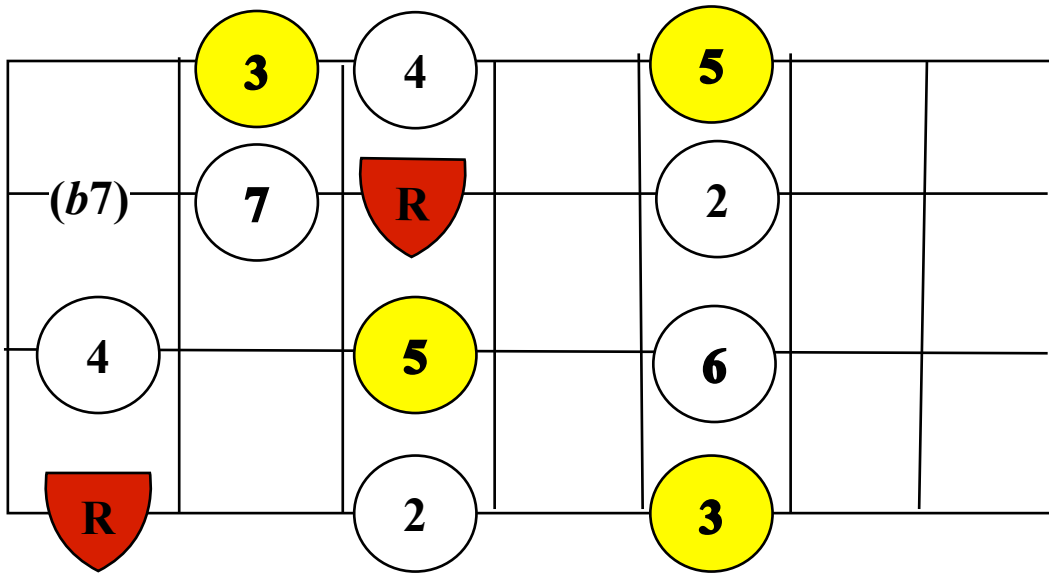

X

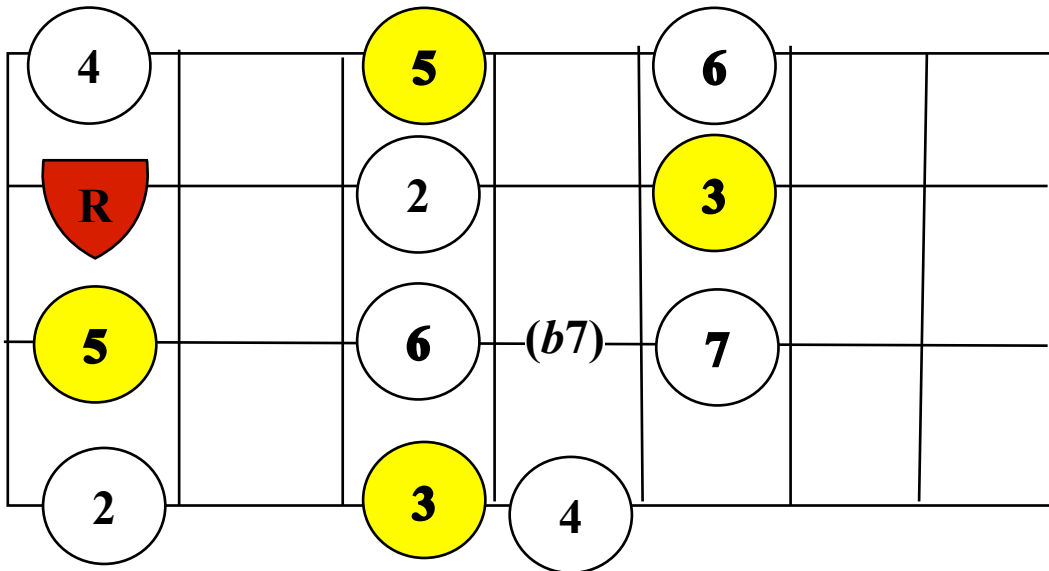

Notice that this is the closed (no open strings) version of the 1st position pattern.
The geometry is the same but the fingering is different. The sequence we've just learned
Starts over from here- there are no new patterns. They just feel a lot smaller.

XII

